

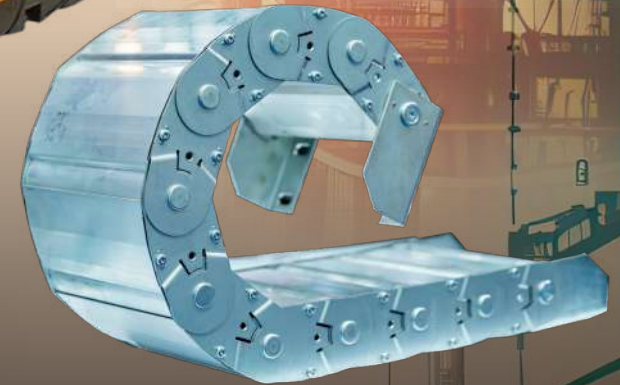

POWERMITE

**ENERGY DRAG CHAINS FOR
INDUSTRIAL APPLICATIONS**



**brevetti
stendaito**
ENERGY IN MOTION

*Reliable Solutions for High-Performance
Cable Management in Motion.*

a member of the **Hudaco** group

335LI ENERGY DRAG CHAIN

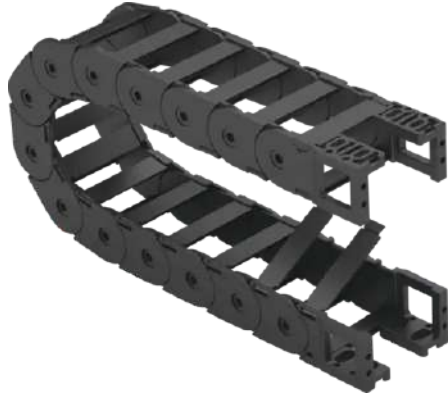

Part No. P8821

Dimension: EXT: 56.5X50mm / INT: 40X35mm
20 LINKS = 1.040MTR

Part No. P8822

Dimension: EXT: 92.5X50mm / INT: 76X35mm
20 LINKS = 1.040MTR

SERIE LIGHT
335LI Nylon Cable Chain

Inner height (D) 35 mm

Single-link construction with opening frames from inner radius. Non-opening version (335L) and version with opening frames from outer radius(335LE) available on request. Vertical separators available.

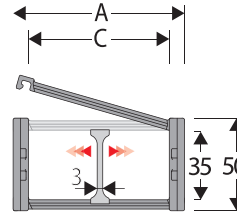

Separator	
- Unassembled	Part.no S4353
- Assembled	Part.no S4353MC

Technical characteristics when self-supported	
Speed	10 m/s
Acceleration	50 m/s ²
For higher requirements please consult our technical dept.	

A mm	B mm	C mm	D mm	R mm	Weight/m kg	Chain
56,5	50	40	35	065-075-100-125-150-200	1,08	335L(LI)(LE)040□□□*
66,5	50	50	35	065-075-100-125-150-200	1,12	335L(LI)(LE)050□□□*
76,5	50	60	35	065-075-100-125-150-200	1,16	335L(LI)(LE)060□□□*
92,5	50	76	35	065-075-100-125-150-200	1,22	335L(LI)(LE)076□□□*
119,5	50	103	35	065-075-100-125-150-200	1,32	335L(LI)(LE)103□□□*
141,5	50	125	35	065-075-100-125-150-200	1,40	335L(LI)(LE)125□□□*
166,5	50	150	35	065-075-100-125-150-200	1,50	335L(LI)(LE)150□□□*

*Complete the code by inserting the value of the radius (R): Ex. 335L(LI)(LE)040 [0][6][5]

R mm	H mm	N mm	M mm	N1 mm	M1 mm
065	180	169	310	220	465
075	200	179	340	260	560
100	250	204	420	350	560
125	300	229	500	445	1025
150	350	254	580	540	1260
200	450	304	735	730	1725

Length of chain (L)
Half travel distance ($\frac{LS}{2}$)
plus length of curve (M) or (M1)
 $L = (\frac{LS}{2}) + M$ or $M1$

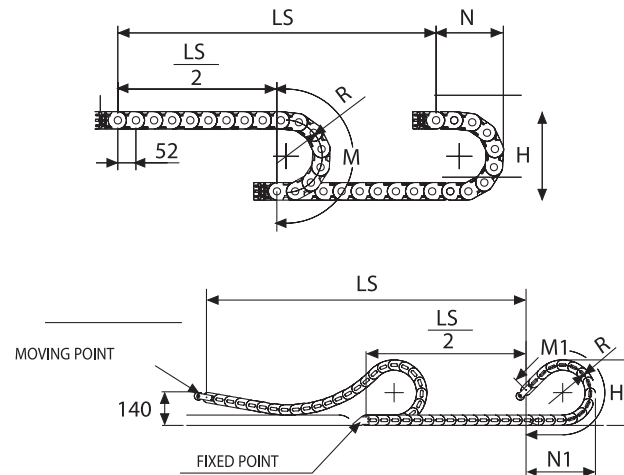

For sliding applications, technical data can slightly change according to frequency, added weight and environment.

SLIDING VERSION
To be ordered with pivoting end brackets set

Self-Supporting Capacity Diagram

The maximum length of the self-supporting capacity ($\frac{LS}{2}$) in relationship to the weight of the cables and hoses contained per linear metre.

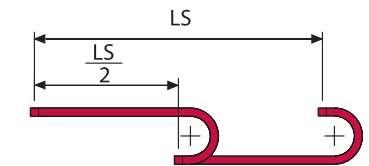
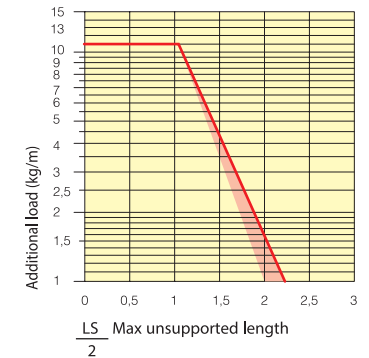

The red marking in the diagram area considers the difference of weight between various widths of chain.

**325LE
ENERGY DRAG CHAIN**



SERIE LIGHT

325LI/325LE Nylon Cable Chain with opening frames

Inner height (D) 25 mm

Single link construction with central large anti-friction pivot, for high torsion and tensile resistance. Frames opening from inner radius (325LI) or from outer radius (325LE).

Vertical separators available. Used with guide channels, this chain is particularly suitable for long distance travel.

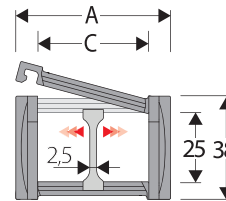

Separator	
- Unassembled	Part.no S325L
- Assembled	Part.no S325LMC

Technical characteristics when self-supported	
Speed	10 m/s
Acceleration	50 m/s ²
For higher requirements please consult our technical dept.	

A mm	B mm	C mm	D mm	R mm	Weight/m kg	Chain
57	38	40	25	050-060-075-100-125-150	0,78	325LI(LE)040□□□*
77	38	60	25	050-060-075-100-125-150	0,90	325LI(LE)060□□□*
93	38	76	25	050-060-075-100-125-150	1,00	325LI(LE)076□□□*
120	38	103	25	050-060-075-100-125-150	1,11	325LI(LE)103□□□*
142	38	125	25	050-060-075-100-125-150	1,20	325LI(LE)125□□□*

*Complete the code by inserting the value of the radius (R): Ex. 325LI040 0|5|0

R mm	H mm	N mm	M mm	N1 mm	M1 mm
050	138	115	250	145	300
060	158	125	280	155	335
075	188	140	325	185	420
100	238	165	405	275	635
125	288	190	485	360	855
150	338	215	565	445	1075

Length of chain (L)
Half travel distance ($\frac{LS}{2}$)
plus length of curve (M) or (M1)
 $L = (\frac{LS}{2}) + M$ or $M1$

Self-Supporting Capacity Diagram

The maximum length of the self-supporting capacity ($\frac{LS}{2}$) in relationship to the weight of the cables and hoses contained per linear metre.

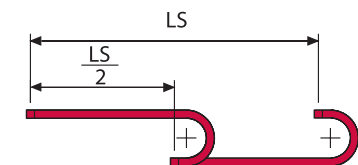
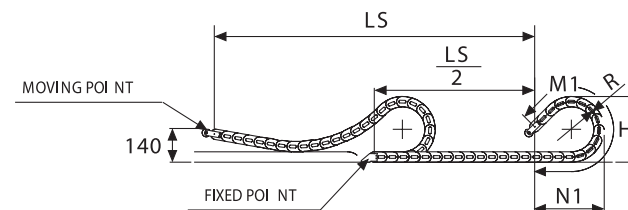
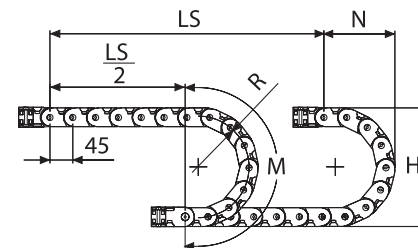
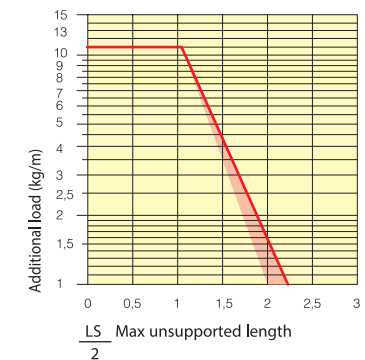

The red marking in the diagram area considers the difference of weight between various widths of chain.

For sliding applications, technical data can slightly change according to frequency, added weight and environment.

SLIDING VERSION
To be ordered with pivoting end brackets set

305A
ENERGY DRAG CHAIN NYLON R120



Part No. P8827

Dimension: EXT: 54X30mm / INT: 30X24mm
28 LINKS = 0.980MTR

Part No. P8828

Dimension: EXT: 74X30mm / INT: 50X24mm
28 LINKS = 0.980MTR

SERIE MEDIUM

305A Nylon Cable Chain with removable frames

Inner height (D) 24 mm

Double share single link joining construction with large anti-friction single-pin. Frames removable from inner radius. Vertical separators are available. Wide frames on outer radius offer good protection. Due to its design with double-share lateral side, the chain is very robust, meanwhile offering very low friction.

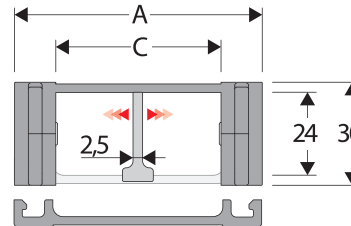

Separator	
- Unassembled	Part.no S305A
- Assembled	Part.no S305AMC
Pin	
	Part.no PG305

Technical characteristics when self-supported	
Speed	10 m/s
Acceleration	50 m/s ²
For higher requirements please consult our technical dept.	

A mm	B mm	C mm	D mm	R mm	Weight/m kg	Chain Part Number
54	30	30	24	50	0,85	305A008
54	30	30	24	70	0,85	305A010
54	30	30	24	120	0,85	305A020
54	30	30	24	150	0,85	305A050
74	30	50	24	50	0,95	305A009
74	30	50	24	70	0,95	305A030
74	30	50	24	120	0,95	305A040
74	30	50	24	150	0,95	305A060

R mm	H mm	N mm	M mm
50	130	105	230
70	170	120	290
120	270	175	450
150	330	205	545

Length of chain (L)
Half travel distance ($\frac{LS}{2}$)
plus length of curve (M) or (M1)

$$L = (\frac{LS}{2}) + M$$

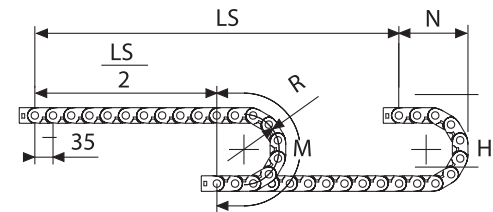

Self-Supporting Capacity Diagram

The maximum length of the self-supporting capacity ($\frac{LS}{2}$) in relationship to the weight of the cables and hoses contained per linear metre.

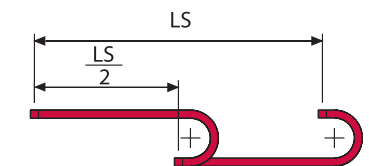
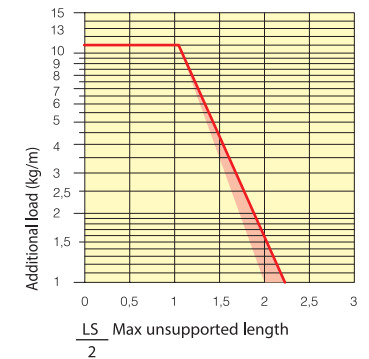

The red marking in the diagram area considers the difference of weight between various widths of chain.

660A ENERGY DRAG CHAIN



Part No. P8826

Dimension: EXT: 150X55mm / INT: 125X37mm

20 LINKS = 1.000MTR

SERIE MEDIUM

660A Nylon Cable Chain with opening frames

Inner height (D) 37 mm

Double share Sideband & Frame construction with large anti-friction single-pin. Frames opening from inner radius. As standard the chain comes with frames every second link, on request with frames every link.

Vertical and horizontal modular separator system is available.

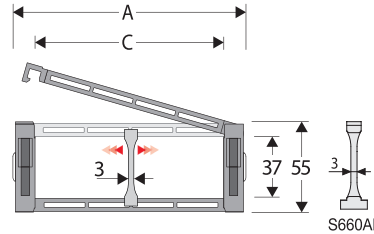

Separator	
- Unassembled	Part.no S306SM
- Assembled	Part.no S306SMMC
Strong-hold separator for C > 200 mm	
- Unassembled	Part.no S660AH
- Assembled	Part.no S306SMMC
Pin	
Part.no PG660	

Technical characteristics when self-supported	
Speed	6 m/s
Acceleration	30 m/s ²
For higher requirements please consult our technical dept.	

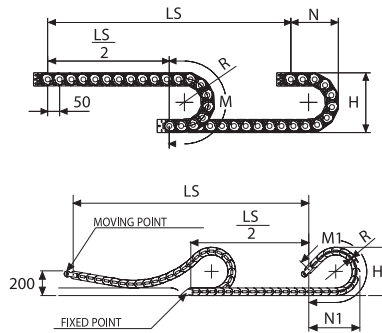

R mm	H mm	N mm	M mm	N1 mm	M1 mm
100	255	180	415	205	470
150	355	230	575	360	855
200	455	280	730	535	1290
250	555	330	885	705	1730

Length of chain (L)

Half travel distance ($\frac{LS}{2}$)

plus length of curve (M) or (M1)

$L = (\frac{LS}{2}) + M$ or $M1$

A mm	B mm	C mm	D mm	R mm	Weight/m kg	Chain
75	55	50	37	100-150-200-250	1,51	660A050□□□*
86	55	61	37	100-150-200-250	1,51	660A061□□□*
100	55	75	37	100-150-200-250	1,59	660A075□□□*
106	55	81	37	100-150-200-250	1,61	660A081□□□*
110	55	85	37	100-150-200-250	1,63	660A085□□□*
120	55	95	37	100-150-200-250	1,66	660A095□□□*
125	55	100	37	100-150-200-250	1,66	660A100□□□*
132	55	107	37	100-150-200-250	1,69	660A107□□□*
142	55	117	37	100-150-200-250	1,71	660A117□□□*
150	55	125	37	100-150-200-250	1,76	660A125□□□*
161	55	136	37	100-150-200-250	1,80	660A136□□□*
175	55	150	37	100-150-200-250	1,84	660A150□□□*
200	55	175	37	100-150-200-250	1,93	660A175□□□*
225	55	200	37	100-150-200-250	2,02	660A200□□□*
236	55	211	37	100-150-200-250	2,06	660A211□□□*
250	55	225	37	100-150-200-250	2,11	660A225□□□*
277	55	252	37	100-150-200-250	2,21	660A252□□□*
286	55	261	37	100-150-200-250	2,24	660A261□□□*
337	55	312	37	100-150-200-250	2,43	660A312□□□*
359	55	334	37	100-150-200-250	2,52	660A334□□□*
387	55	362	37	100-150-200-250	2,61	660A362□□□*

*Complete the code by inserting the value of the radius (R): Ex. 660A050 1 5 0
Chain equipped with nylon frame every pitch: complete the code by inserting the letter D.
Ex. 660A050150 D

Self-Supporting Capacity Diagram

The maximum length of the self-supporting capacity ($\frac{LS}{2}$) in relationship to the weight of the cables and hoses contained per linear metre.

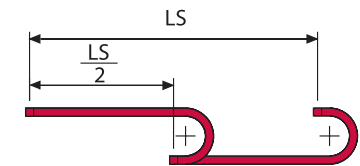
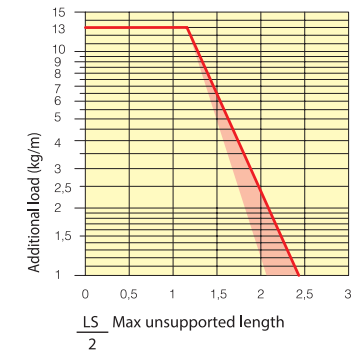

The red marking in the diagram area considers the difference of weight between various widths of chain.

For sliding applications, technical data can slightly change according to frequency, added weight and environment.

SLIDING VERSION
To be ordered with pivoting end brackets set

305 ENERGY DRAG CHAIN NYLON



Part No. P8831

Dimension: EXT: 54X30mm / INT: 30X23mm

28 LINKS = 0.980MTR

SERIE MEDIUM
305 Nylon Cable Chain

Inner height (D) 23 mm

Double share single link joining construction with large anti-friction single-pin. Non-opening. Vertical separators are available. Due to its design with double-share lateral side, the chain is very robust, meanwhile offering very low friction. Used with guide channels, this chain is particularly suitable for long distance travel.

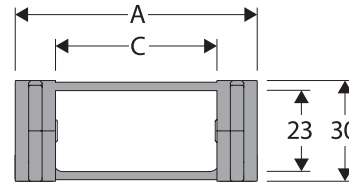

Separator*	
- Unassembled	Part.no S4353
- Assembled	Part.no S4353MC
Pin	
	Part.no PG305

*Separator not to be used in long-stroke applications

A mm	B mm	C mm	D mm	R mm	Weight/m kg	Chain Part Number
54	30	30	23	50	0,90	305008
54	30	30	23	70	0,90	305010
54	30	30	23	120	0,90	305020
54	30	30	23	150	0,90	305050
74	30	50	23	50	1,00	305009
74	30	50	23	70	1,00	305030
74	30	50	23	120	1,00	305040
74	30	50	23	150	1,00	305060

Technical characteristics when self-supported	
Speed	10 m/s
Acceleration	50 m/s ²
For higher requirements please consult our technical dept.	

R mm	H mm	N mm	M mm	N1 mm	M1 mm
50	130	105	230	125	270
70	170	120	290	160	365
120	270	175	450	330	800
150	330	205	545	435	1065

Length of chain (L)
Half travel distance ($\frac{LS}{2}$)
plus length of curve (M) or (M1)
 $L = (\frac{LS}{2}) + M$ or $M1$

For sliding applications, technical data can slightly change according to frequency, added weight and environment.

SLIDING VERSION
To be ordered with pivoting end brackets set

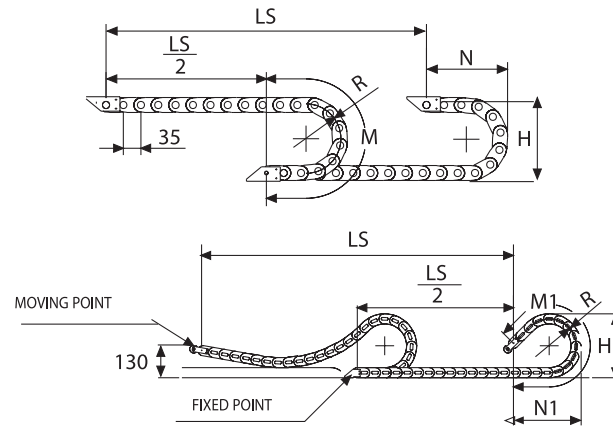

Self-Supporting Capacity Diagram

The maximum length of the self-supporting capacity ($\frac{LS}{2}$) in relationship to the weight of the cables and hoses contained per linear metre.

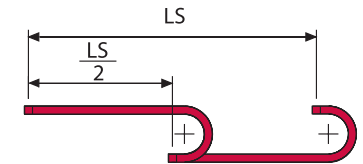
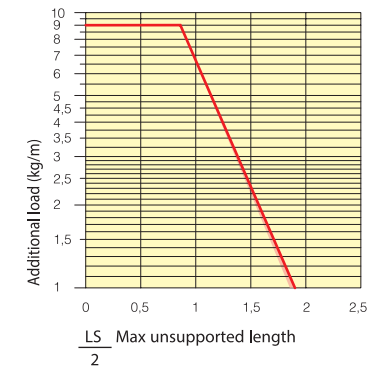

The red marking in the diagram area considers the difference of weight between various widths of chain.

355A
ENERGY DRAG CHAIN NYLON



Part No. P8832

Dimension: EXT: 74X43mm / INT: 45X31mm

25 LINKS = 1.000MTR

SERIE MEDIUM

355A Nylon Cable Chain with removable frames

Inner height (D) 31 mm

Double share single link joining construction with large anti-friction single-pin. Frames removable from inner radius. Vertical separators are available. Wide frames on outer radius offer good protection. Due to its design with double-share lateral side, the chain is very robust, meanwhile offering very low friction.

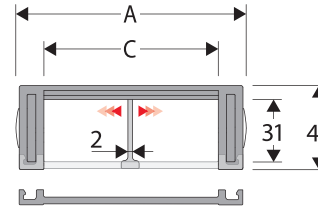

Separator	
- Unassembled	Part.no S355
- Assembled	Part.no S355MC
Pin	
	Part.no PG355

Technical characteristics when self-supported	
Speed	10 m/s
Acceleration	50 m/s ²
For higher requirements please consult our technical dept.	

A mm	B mm	C mm	D mm	R mm	Weight/m kg	Chain Part Number
74	43	45	31	75	1,40	355A045
74	43	45	31	100	1,40	355A046
74	43	45	31	150	1,40	355A047
74	43	45	31	200	1,40	355A048
94	43	65	31	75	1,50	355A065
94	43	65	31	100	1,50	355A066
94	43	65	31	150	1,50	355A067
94	43	65	31	200	1,50	355A068
124	43	95	31	75	1,70	355A095
124	43	95	31	100	1,70	355A096
124	43	95	31	150	1,70	355A097
124	43	95	31	200	1,70	355A098

R mm	H mm	N mm	M mm
75	194	140	315
100	244	165	395
150	344	215	555
200	444	265	710

Length of chain (L)

Half travel distance ($\frac{LS}{2}$)

plus length of curve (M) or (M1)

$$L = \left(\frac{LS}{2}\right) + M$$

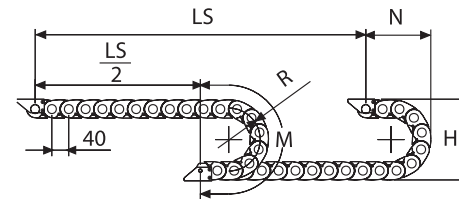

Self-Supporting Capacity Diagram

The maximum length of the self-supporting capacity ($\frac{LS}{2}$) in relationship to the weight of the cables and hoses contained per linear metre.

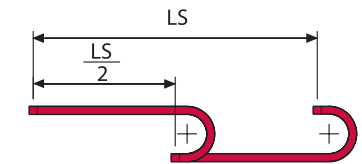
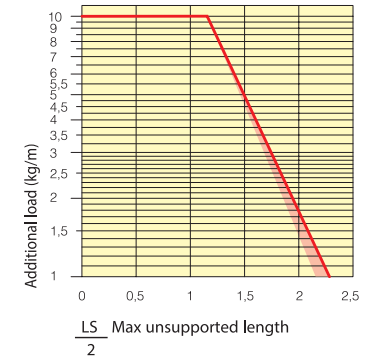

The red marking in the diagram area considers the difference of weight between various widths of chain.

306SU
ENERGY DRAG CHAIN NYLON



SERIE HEAVY

306SU Nylon Cable Chain with opening frames

Inner height (D) 37 mm

Strong double share Sideband & Frame construction with large anti-friction triple-pin. Frames opening from inner and outer radius. As standard the chain comes with frames every second link, on request with frames every link. Vertical and horizontal modular separator system is available.

Technical characteristics when self-supported	
Speed	4 m/s
Acceleration	10 m/s ²
For higher requirements please consult our technical dept.	

R mm	H mm	N mm	M mm
075	194	140	315
107	244	165	395
150	344	215	555
200	444	265	710
250	558	345	920
300	658	395	1075

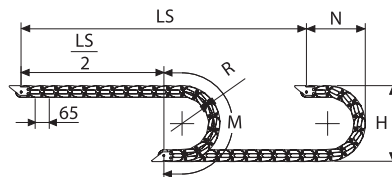

Length of chain (L)
Half travel distance ($\frac{LS}{2}$)
plus length of curve (M) or (M1)

$$L = \left(\frac{LS}{2}\right) + M$$

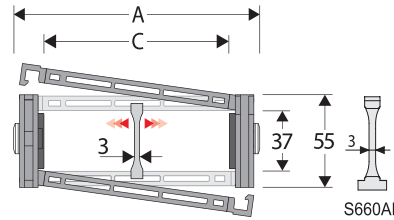

Separator	
- Unassembled	Part.no S4353
- Assembled	Part.no S4353MC
Strong-hold separator for C > 250 mm	
- Unassembled	Part.no S660AH
- Assembled*	Part.no S660AHMCI
- Assembled**	Part.no S660AHMCE
Pin	
Part.no PG307	

* for chain opening outer radius
** for chain opening inner radius

391A mm	B mm	C mm	D mm	R mm	Weight/m kg	Chain
79	55	43	37	075-107-150-200-250-300	1,61	306SU043□□□*
90	55	54	37	075-107-150-200-250-300	1,61	306SU054□□□*
104	55	68	37	075-107-150-200-250-300	1,68	306SU068□□□*
110	55	74	37	075-107-150-200-250-300	1,70	306SU074□□□*
114	55	78	37	075-107-150-200-250-300	1,72	306SU078□□□*
124	55	88	37	075-107-150-200-250-300	1,74	306SU088□□□*
129	55	93	37	075-107-150-200-250-300	1,74	306SU093□□□*
136	55	100	37	075-107-150-200-250-300	1,76	306SU100□□□*
146	55	110	37	075-107-150-200-250-300	1,77	306SU110□□□*
154	55	118	37	075-107-150-200-250-300	1,82	306SU118□□□*
165	55	129	37	075-107-150-200-250-300	1,85	306SU129□□□*
179	55	143	37	075-107-150-200-250-300	1,89	306SU143□□□*
204	55	168	37	075-107-150-200-250-300	1,96	306SU168□□□*
229	55	193	37	075-107-150-200-250-300	2,04	306SU193□□□*
240	55	204	37	075-107-150-200-250-300	2,07	306SU204□□□*
254	55	218	37	075-107-150-200-250-300	2,11	306SU218□□□*
281	55	245	37	075-107-150-200-250-300	2,19	306SU245□□□*
290	55	254	37	075-107-150-200-250-300	2,22	306SU254□□□*
315	55	297	37	075-107-150-200-250-300	2,29	306SU279□□□*
341	55	305	37	075-107-150-200-250-300	2,34	306SU305□□□*
363	55	327	37	075-107-150-200-250-300	2,41	306SU327□□□*
391	55	355	37	075-107-150-200-250-300	2,49	306SU355□□□*

*Complete the code by inserting the value of the radius (R): Ex. 306SU110 [1][5][0]
Chain equipped with nylon frame every pitch: complete the code by inserting the letter D.
Ex. 306SU110150 [D]

Self-Supporting Capacity Diagram

The maximum length of the self-supporting capacity ($\frac{LS}{2}$) in relationship to the weight of the cables and hoses contained per linear metre.

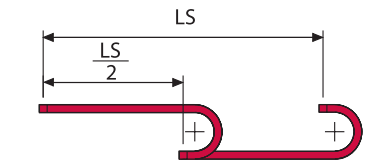
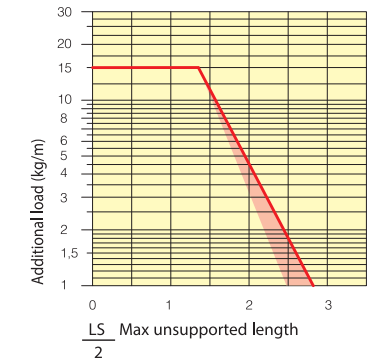

The red marking in the diagram area considers the difference of weight between various widths of chain.

400 ENERGY DRAG CHAIN NYLON R100



Part No. P8829

Dimension: EXT: 82X35mm / INT: 60X25mm
25 LINKS = 1.000MTR

Part No. P8830

Dimension: EXT: 82X35mm / INT: 60X25mm
25 LINKS = 1.000MTR

SERIE MEDIUM

400 Nylon Cable Chain with removable frames

Inner height (D) 25 mm

Double share single link joining construction with large anti-friction single-pin. Frames removable from inner radius. Vertical separators are available. Wide frames on outer radius offer good protection. Due to its design with double-share lateral side, the chain is very robust, meanwhile offering very low friction.

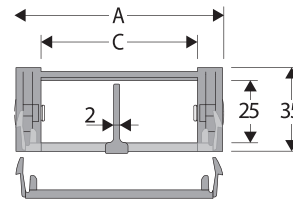

Separator	
- Unassembled	Part.no S400
- Assembled	Part.no S400MC
Pin	
	Part.no PG305

Technical characteristics when self-supported	
Speed	10 m/s
Acceleration	50 m/s ²
For higher requirements please consult our technical dept.	

A mm	B mm	C mm	D mm	R mm	Weight/m kg	Chain Part Number
62	35	40	25	50	1,10	400040
62	35	40	25	75	1,10	400041
62	35	40	25	100	1,10	400042
62	35	40	25	150	1,10	400043
82	35	60	25	50	1,25	400060
82	35	60	25	75	1,25	400061
82	35	60	25	100	1,25	400062
82	35	60	25	150	1,25	400063

R mm	H mm	N mm	M mm
50	138	110	240
75	188	135	315
100	238	160	395
150	338	210	555

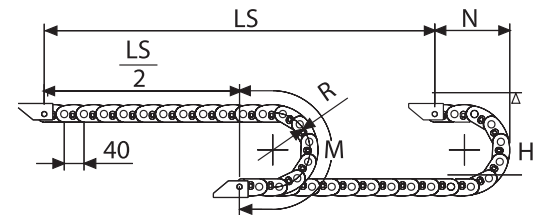

Self-Supporting Capacity Diagram

The maximum length of the self-supporting capacity ($\frac{LS}{2}$) in relationship to the weight of the cables and hoses contained per linear metre.

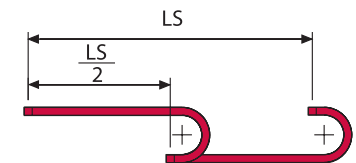
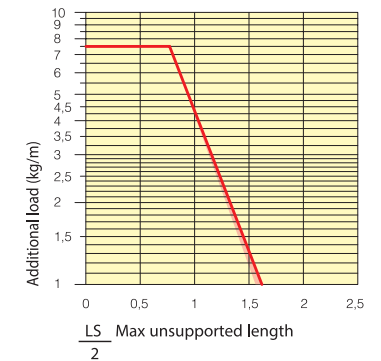

The red marking in the diagram area considers the difference of weight between various widths of chain.

Length of chain (L)
Half travel distance ($\frac{LS}{2}$)
plus length of curve (M) or (M1)

$L = (\frac{LS}{2}) + M$ or $M1$

**H57SC
ENERGY DRAG CHAIN NYLON**



SERIE HEAVY

H57SC Nylon Cable Chain with opening frames

Inner height (D) 57 mm

Sideband construction with quick removable pin. Frames openable from either side on both inner and outer radius. As standard the chain comes with frames every second link, on request with frames every link.

Vertical and horizontal modular separator system is available.

Technical characteristics when self-supported	
Speed	8 m/s
Acceleration	40 m/s ²
For higher requirements please consult our technical dept.	

For sliding applications, characteristics techniques may vary depending on the frequency, added weight and work environment.

R mm	H mm	N mm	M mm	N1 mm	M1 mm
150	385	283	655	565	1235
180	445	313	750	705	1570
200	485	333	810	805	1605
250	585	383	970	1040	2350
300	685	483	1125	1275	2905
350	785	483	1280	1510	3460
400	885	533	1440	1750	4020

Length of chain (L)

Half travel distance ($\frac{LS}{2}$)

plus length of curve (M) or (M1)

$$L = \left(\frac{LS}{2}\right) + M \text{ or } M1$$

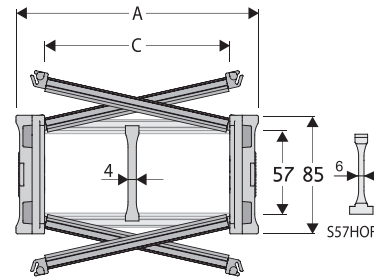

Separator	
- Unassembled	Part.no S57CF3
- Assembled*	Part.no S57CF3MCI
- Assembled**	Part.no S57CF3MCE
Strong-hold Separator for C > 250 mm	
- Unassembled	Part.no S57CF3
- Assembled*	Part.no S57CF3MCI
Pin	
Part.no PNH57RS	

* for chain opening outer radius
** for chain opening inner radius

A mm	B mm	C mm	D mm	R mm	Weight/m kg	Chain
113	85	75	57	150-180-200-250-300-350-400	3,03	H57SC075□□□*
138	85	100	57	150-180-200-250-300-350-400	3,09	H57SC100□□□*
163	85	120	57	150-180-200-250-300-350-400	3,16	H57SC125□□□*
188	85	150	57	150-180-200-250-300-350-400	3,22	H57SC150□□□*
213	85	175	57	150-180-200-250-300-350-400	3,29	H57SC175□□□*
238	85	200	57	150-180-200-250-300-350-400	3,35	H57SC200□□□*
263	85	225	57	150-180-200-250-300-350-400	3,42	H57SC225□□□*
288	85	250	57	150-180-200-250-300-350-400	3,48	H57SC250□□□*
313	85	275	57	150-180-200-250-300-350-400	3,55	H57SC275□□□*
338	85	300	57	150-180-200-250-300-350-400	3,61	H57SC300□□□*
388	85	350	57	150-180-200-250-300-350-400	3,74	H57SC350□□□*
438	85	400	57	150-180-200-250-300-350-400	3,88	H57SC400□□□*

*Complete the code by inserting the value of the radius (R): Ex. H57SC100[2][5][0]
Chain equipped with nylon frame every pitch: complete the code by inserting the letter D. Ex. H57SC100250[D]

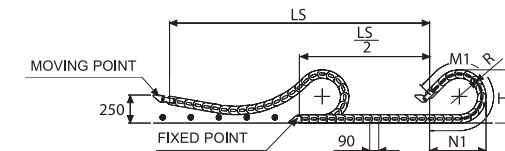
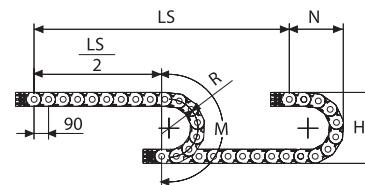

Self-Supporting Capacity Diagram

The maximum length of the self-supporting capacity ($\frac{LS}{2}$) in relationship to the weight of the cables and hoses contained per linear metre.

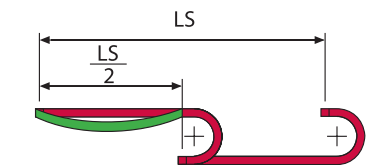
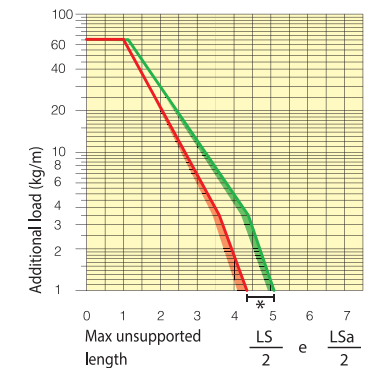

The red marking in the diagram area considers the difference of weight between various widths of chain.

Part No. P8835
Dimension: EXT: 138X85mm / INT: 100X57mm
11 LINKS = 0.990MTR
Part No. P8836
Dimension: EXT: 188X85mm / INT: 150X57mm
11 LINKS = 0.990MTR
Part No. P8837
Dimension: EXT: 238X85mm / INT: 200X57mm
11 LINKS = 0.990MTR
Part No. P8838
Dimension: EXT: 138X85mm / INT: 100X57mm
11 LINKS = 0.990MTR
Part No. P8839
Dimension: EXT: 238X85mm / INT: 200X57mm
11 LINKS = 0.990MTR

H45SC
ENERGY DRAG CHAIN NYLON



Part No. P8840 Dimension: EXT: 138X70mm / INT: 100X45mm 13 LINKS = 0.975MTR	Part No. P8846 Dimension: EXT: 188X70mm / INT: 150X45mm 13 LINKS = 0.975MTR
Part No. P8841 Dimension: EXT: 163X70mm / INT: 125X45mm 13 LINKS = 0.975MTR	Part No. P8847 Dimension: EXT: 213X70mm / INT: 175X45mm 13 LINKS = 0.975MTR
Part No. P8842 Dimension: EXT: 188X70mm / INT: 150X45mm 13 LINKS = 0.975MTR	Part No. P8848 Dimension: EXT: 138X70mm / INT: 100X45mm 13 LINKS = 0.975MTR
Part No. P8843 Dimension: EXT: 213X70mm / INT: 175X45mm 13 LINKS = 0.975MTR	Part No. P8849 Dimension: EXT: 163X70mm / INT: 125X45mm 13 LINKS = 0.975MTR
Part No. P8844 Dimension: EXT: 138X70mm / INT: 100X45mm 13 LINKS = 0.975MTR	Part No. P8850 Dimension: EXT: 188X70mm / INT: 150X45mm 13 LINKS = 0.975MTR
Part No. P8845 Dimension: EXT: 163X70mm / INT: 125X45mm 13 LINKS = 0.975MTR	Part No. P8851 Dimension: EXT: 213X70mm / INT: 175X45mm 13 LINKS = 0.975MTR

SERIE MEDIUM
305 Nylon Cable Chain

Inner height (D) 23 mm

Double share single link joining construction with large anti-friction single-pin. Non-opening. Vertical separators are available. Due to its design with double-share lateral side, the chain is very robust, meanwhile offering very low friction. Used with guide channels, this chain is particularly suitable for long distance travel.

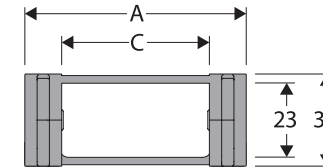

Separator	
- Unassembled	Part.no S305
- Assembled	Part.no S305MC
Pin	
	Part.no PG305

*Separator not to be used in long-stroke applications

Technical characteristics when self-supported	
Speed	10 m/s
Acceleration	50 m/s ²
For higher requirements please consult our technical dept.	

A mm	B mm	C mm	D mm	R mm	Weight/m kg	Chain Part Number
54	30	30	23	50	0,90	305008
54	30	30	23	70	0,90	305010
54	30	30	23	120	0,90	305020
54	30	30	23	150	0,90	305050
74	30	50	23	50	1,00	305009
74	30	50	23	70	1,00	305030
74	30	50	23	120	1,00	305040
74	30	50	23	150	1,00	305060

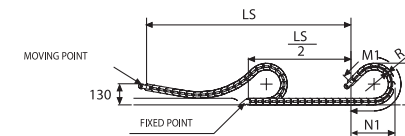
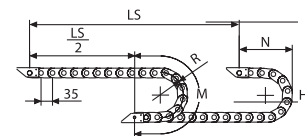

R mm	H mm	N mm	M mm	N1 mm	M1 mm
50	130	105	230	125	270
70	170	120	290	160	365
120	270	175	450	330	800
150	330	205	545	435	1065

Length of chain (L)
Half travel distance ($\frac{LS}{2}$)
plus length of curve (M) or (M1)
 $L = (\frac{LS}{2}) + M$ or $M1$

Self-Supporting Capacity Diagram

The maximum length of the self-supporting capacity ($\frac{LS}{2}$) in relationship to the weight of the cables and hoses contained per linear metre.

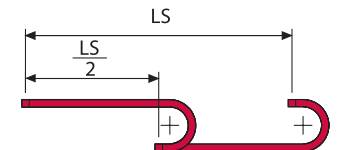
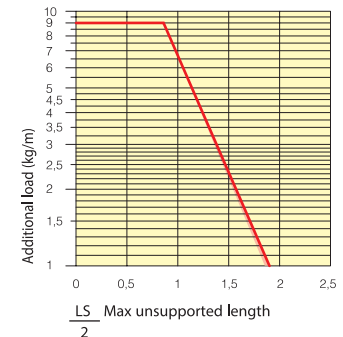

The red marking in the diagram area considers the difference of weight between various widths of chain.

For sliding applications, technical data can slightly change according to frequency, added weight and environment.

SLIDING VERSION
To be ordered with pivoting end brackets set

335L040
NYLON END BRACKET SET



Part No. P8852

335L076
NYLON END BRACKET SET



Part No. P8853

325L103
NYLON END BRACKET SET



Part No. P8854

325L125
NYLON END BRACKET SET



Part No. P8855

325L040
NYLON END BRACKET SET



Part No. P8856

660A
STEEL END BRACKET SET



Part No. P8857

305
NYLON END BRACKET SET



Part No. P8858

400 NYLON
END BRACKET SET



Part No. P8859

355
NYLON END BRACKET SET



Part No. P8860

306
NYLON END BRACKET SET



Part No. P8861

H57
NYLON END BRACKET SET



Part No. P8862

H45SC100
NYLON END BRACKET SET



Part No. P8863

H45SC125
NYLON END BRACKET SET



Part No. P8864

H45SC150
NYLON END BRACKET SET



Part No. P8865

H45SC175
NYLON END BRACKET SET



Part No. P8866

435
VERTICAL SEPARATOR 3 LOBES



Part No. P8867

S325L
VERTICAL SEPARATOR



Part No. P8868

S306SM
SEPARATOR 306-660A 1 HOLE



Part No. P8869

S305A
VERTICAL SEPARATOR



Part No. P8870

S305A
VERTICAL SEPARATOR



Part No. P8871

355
VERTICAL SEPARATOR



Part No. P8872

H57
VERTICAL SEPARATOR 3 HOLES D 4,5 MM



Part No. P8873

45
VERTICAL SEPARATOR 3 HOLES D 4,5 MM



Part No. P8874

A fundamental element in cable chains is the pre-set Z (Fig. A).

This determines the self-supporting capacity, a characteristic which allows the cable chain to support not only its own weight, but also the weight of the cables/hoses placed in it and to keep its parallel or slightly curved upward position (Fig. B).

The diagram of self-supporting capacity (Fig. C), indicates the weight relation of cables/hoses per linear meter to the lengths of self-supporting chain travel.

The red-area indicates the difference between min/max chain widths, while the widest version has the lowest self-support capacity. With the application of cable chains with $\frac{LS}{2}$ and weights not included in the area of the diagram of

self-supporting capacity, it's necessary to use the appropriate support rollers, in order to confirm chain reliability in exceptional applications.

All the H-heights reported into this catalogue are not including any Z-value due to the preload, therefore, whenever limitations to the maximum allowable height are required, you should refer to Brevetti Stendalto's Technical Dptm.

Brevetti Stendalto chains, thanks to their specific construction, reach remarkably high values of self-supporting capacity and acceleration with long periods of motion, reaching millions of cycles.

For particular applications (e.g. vertical travel), the chains can be provided without pre-set.

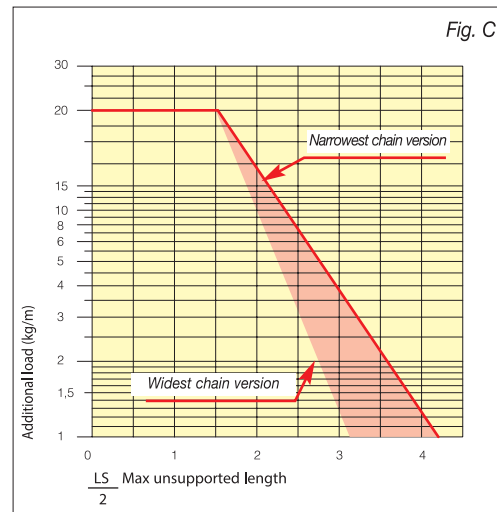
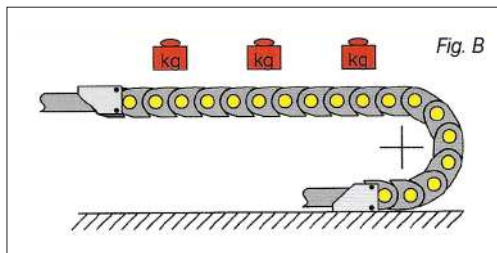
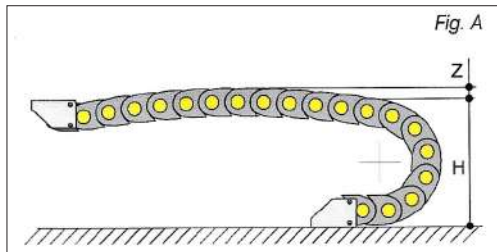

Determining the Chain length

Fixed point at the centre of total travel.

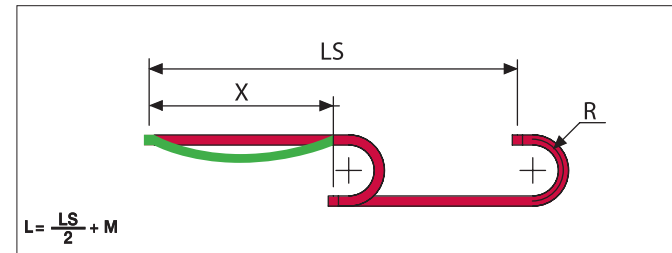

The chain length (L) is calculated by summarising the half stroke $\frac{LS}{2}$ to the nominal value (M) of the bending radius.

The value is then rounded up the multiply of the chain's pitch for nylon cable chains and to an odd multiply for steel chains.

Fixed point not positioned at the centre of total travel.

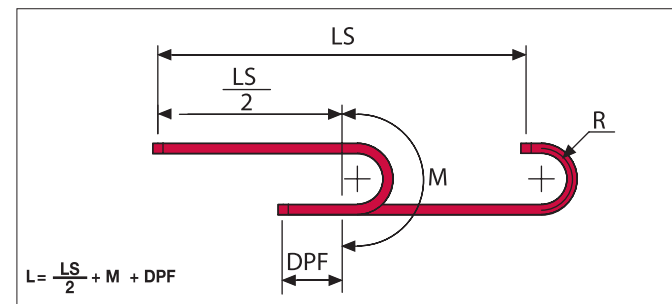

The chain length (L) is calculated by summarising the half stroke $\frac{LS}{2}$ to the nominal value (M) of the bending radius and the distance (DPF) from fixed point to centre of total stroke.

The value is then rounded up the multiply of the chain's pitch for nylon cable chains and to an odd multiply for steel chains.

Where:

L = Length of chain

$\frac{LS}{2}$ = Half travel distance

M = Length of curve ($\pi \times R$) + (2 x P)

DPF = Distance from fixed point to centre of total stroke

P = Pitch

POWERMITE



Head Office
☎ +27 11 271 0000
✉ info@powermite.co.za

Cape Town
☎ +27 21 951 1505
✉ powermite.ct@powermite.co.za

Richards Bay
☎ +27 35 751 1213/6
✉ powermite.rbay@powermite.co.za

Durban Riverhorse Valley
☎ +27 31 700 6830/4
✉ powermite.dbn@powermite.co.za

www.powermite.co.za

REV/0/2/2025